

## LEDCHAN250 RECESSED INSTALLATION INSTRUCTIONS

### Extrusion installation:

Tools required:

- #4 gauge fixing screws maximum - for clip fastening.
- If clips are not used, and direct mounting is desired:  
Pilot drill and countersink - suitable for aluminium,  
matched to #4 gauge countersunk screws.

- 1) Carefully mark out on the panel surface a faint centre line / laser line to position the luminaire in the room.
- 2) The width of the cutout required will vary depending on the fixing method used:

- |                |                          |
|----------------|--------------------------|
| For glue fix:  | 24-27mm wide, 9mm deep   |
| For screw fix: | 24-27mm wide, 8.5mm deep |
| For tape fix:  | 24-27mm wide, 8.5mm deep |
| For clip fix:  | Must be 27mm, 11mm deep. |

\*Note: If the groove is narrower than 27mm the clip will struggle to expand. If wider and not perfectly straight, the groove may become exposed to view. See *fig 1*.

- 3) The end of the groove must be finished to an accurate final dimension. This is determined by your measured length of the extrusion PLUS end caps.

For the end caps to cover the groove a small radius of less than 3mm may remain. See *fig 2*.

- 4) After the groove has been established you can make a detail to accommodate the cable exit from the extrusion.

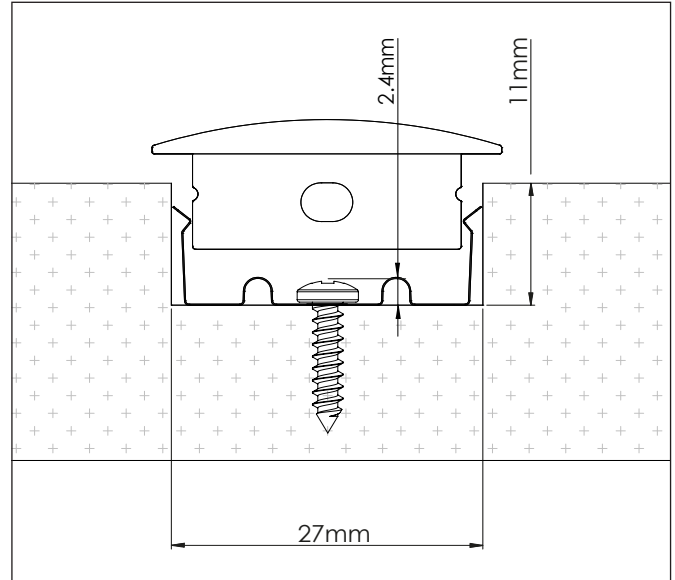

*fig 1. channel with spring clip expanded*

- 5) If screw fix method is to be used select the smallest available screws that will adequately retain the extrusion. These must be of a countersunk type in either #3 gauge or #4 gauge size. The LED strip must be allowed to lie flat against the extrusion. This not only preserves the thermal pathway for the LEDs, but also prevents any strange optical artefacts from being visible in the result.

- 7) Read separate Electrical Installation Instructions for subsequent electrical assembly.

Notes:

- Cover diffusers are not UV stabilized and will become brittle in outdoor environments.
- Drivers are remote mounted only

*fig 2. Channel end detail*

