

LEDCHAN650 RECESSED INSTALLATION INSTRUCTIONS

Extrusion installation:

Tools required:

- #3 gauge pan head screws maximum for clips.
- Direct screw fixing is not possible.

1) Carefully mark out on the panel surface a faint centre line / laser line to position the luminaire in the room.

2) The width of the cutout required can vary depending on the fixing method used:

- For glue fix: 8mm wide, 6.5mm deep
 For tape fix: 8mm wide, 6mm deep
 For clip fix: Must be 10mm, 7mm deep.

*Note: If the groove is narrower than 10mm the clip will struggle to expand. If wider and not perfectly straight. The ears of the clips will protrude from the finished surface.

3) The end of the groove must be finished to an accurate final dimension. This is determined by your measured length of the extrusion PLUS end caps.

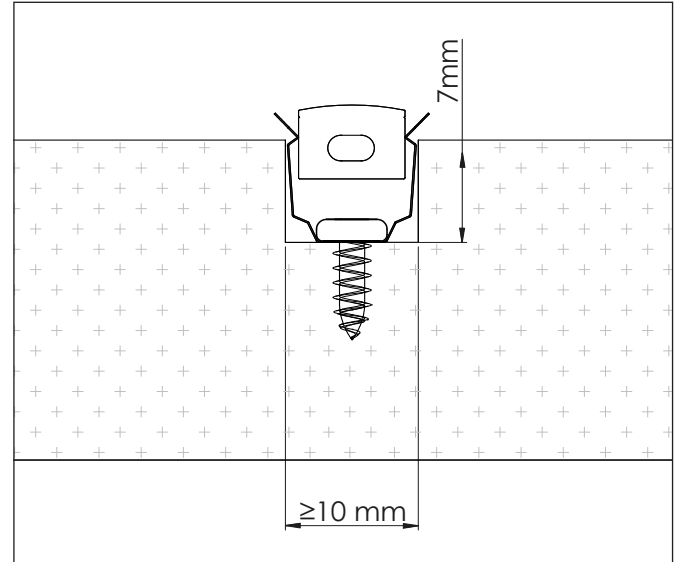

fig 1. channel with spring clip expanded

4) After the groove has been established you can make a detail to accommodate the cable exit from the extrusion.

5) Read separate Electrical Installation Instructions for subsequent electrical assembly.

Notes:

- Cover diffusers are not UV stabilized and will become brittle in outdoor environments.
- Drivers are remote mounted only

fig 2. Channel end detail

