

LEDCHAN170 CORNER MOUNTED INSTALLATION INSTRUCTIONS

Extrusion installation:

Tools required:

- #4 gauge countersunk screws maximum for clips.
- Glue or tape fix may also be appropriate.

Direct screw fix method is not appropriate.

2) Mitred corners, if required, need to be very accurate in order to have tight joints and low light leakage. Task recommends cutting the diffusers mounted in an off-cut of channel for workholding. All cuts should be made slowly on a quality compound drop saw.

3) Leave a small 1mm gap between the free leaf of the clip and the adjacent surface - for spring flex.

4) Read separate Electrical Installation Instructions for subsequent electrical assembly.

Notes:

- Cover diffusers are not UV stabilized and will become brittle in outdoor environments.
- Drivers are remote mounted only

fig 1. channel winstalled with clips

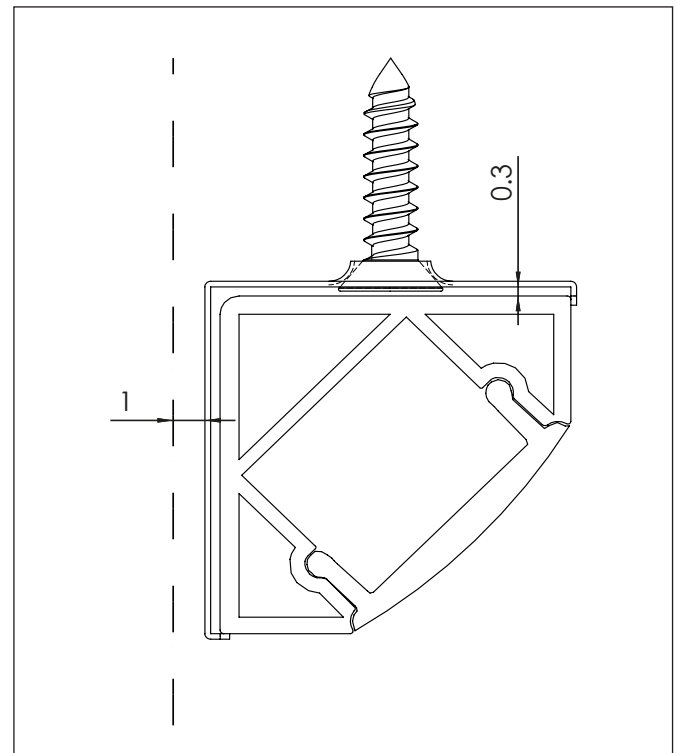

fig 2. Channel end detail showing clip and countersunk screw

