

LEDCHAN590 SUSPENSION MOUNTED INSTALLATION INSTRUCTIONS

Extrusion installation:

1) Carefully mark out on the ceiling surface a faint centre line or laser-line to position the luminaires in the room. In some instances, such as for a pitched ceiling, you may wish to mark it out on the floor, and either shoot a laser up, or drop a plumb-line to your marks.

2) Plan to drop a suspension cable approximately every 2 meters.

3) Mitred corners need to be very accurate in order to have tight joints and low light leakage. Task recommends cutting the diffusers mounted in an off-cut of channel for workholding. All cuts should be made slowly on a quality compound drop saw. Back fill the joints with adhesive foil tape to eliminate light leakage from the joint.

4) Assemble extrusions to suspensions as per the exploded diagram *fig 1*.

Cable length can be adjusted to final height by pulling the tail through the clasp where it exits. Cut excess cable with suitable nippers, pliers, or cable shears. Cable wrapped in masking tape can be cut with a cut-off wheel.

5) Read separate Electrical Installation Instructions for subsequent electrical assembly.

Notes:

- Cover diffusers are not UV stabilized and will become brittle in outdoor environments.
- Drivers are remote mounted only
- Ceiling rose is not supplied

fig 2. Channel end detail showing suspension cable tail exiting the clasp

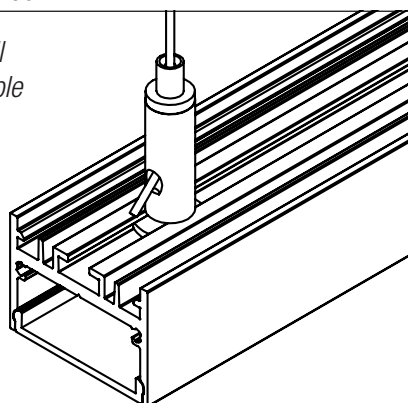

fig 1. Suspension cable assembly

